



MIAMI-DADE COUNTY
 PRODUCT CONTROL SECTION
 11805 SW 26 Street, Room 208
 Miami, Florida 33175-2474
 T (786) 315-2590 F (786) 315-2599
www.miamidade.gov/economy

DEPARTMENT OF REGULATORY AND ECONOMIC RESOURCES (RER)
 BOARD AND CODE ADMINISTRATION DIVISION
NOTICE OF ACCEPTANCE (NOA)

DAB Door Company, Inc.
 12195 NW 98th Avenue
 Hialeah Gardens, FL 33018

SCOPE:

This NOA is being issued under the applicable rules and regulations governing the use of construction materials. The documentation submitted has been reviewed and accepted by Miami-Dade County RER-Product Control Section to be used in Miami-Dade County and other areas where allowed by the Authority Having Jurisdiction (AHJ).

This NOA shall not be valid after the expiration date stated below. The Miami-Dade County Product Control Section (In Miami-Dade County) and/or the AHJ (in areas other than Miami-Dade County) reserve the right to have this product or material tested for quality assurance purposes. If this product or material fails to perform in the accepted manner, the manufacturer will incur the expense of such testing and the AHJ may immediately revoke, modify, or suspend the use of such product or material within their jurisdiction. RER reserves the right to revoke this acceptance if it is determined by Miami-Dade County Product Control Section that this product or material fails to meet the requirements of the applicable building code.

This product is approved as described herein and has been designed to comply with the Florida Building Code, including the High Velocity Hurricane Zone.

DESCRIPTION: Hurricane Master Model 824/811 Steel Sectional Garage Door up to 16'-2" Wide w/ Window Lite Option (DP +56.0, -64.0 PSF)

APPROVAL DOCUMENT: Drawing No. **00-18**, titled "Sectional Garage Door", sheets 1 through 5 of 5, dated 08/24/2000, with last revision **K** dated 06/19/2023, prepared by Al-Farooq Corporation, signed and sealed by Jalal Farooq, P.E. on 06/22/2023, bearing the Miami-Dade County Product Control revision stamp with the Notice of Acceptance number and the expiration date by the Miami-Dade County Product Control Section.

MISSILE IMPACT RATING: Large and Small Missile Impact Resistant

LABELING: A permanent label with the manufacturer's name or logo, manufacturing address, model number, the positive and negative design pressure rating, indicate impact rated if applicable, installation instruction drawing reference number, approval number (NOA), the applicable test standards, and the statement reading 'Miami-Dade County Product Control Approved' is to be located on the door's side track, bottom angle, or inner surface of a panel.

RENEWAL of this NOA shall be considered after a renewal application has been filed and there has been no change in the applicable building code negatively affecting the performance of this product.

TERMINATION of this NOA will occur after the expiration date or if there has been a revision or change in the materials, use, and/or manufacture of the product or process. Misuse of this NOA as an endorsement of any product, for sales, advertising or any other purposes shall automatically terminate this NOA. Failure to comply with any section of this NOA shall be cause for termination and removal of NOA.

ADVERTISEMENT: The NOA number preceded by the words Miami-Dade County, Florida, and followed by the expiration date may be displayed in advertising literature. If any portion of the NOA is displayed, then it shall be done in its entirety.

INSPECTION: A copy of this entire NOA shall be provided to the user by the manufacturer or its distributors and shall be available for inspection at the job site at the request of the Building Official.

This NOA **revises** NOA #20-0929.12 and consists of this page 1 and evidence pages E-1, E-2, E-3 and E-4, as well as approval document mentioned above.

The submitted documentation was reviewed by **Helmy A. Makar, P.E., M.S.**



Helmy A. Makar
 08/10/2023

NOA No. 23-0710.18
 Expiration Date: 02/22/2025
 Approval Date: 08/10/2023
 Page 1

NOTICE OF ACCEPTANCE: EVIDENCE SUBMITTED

1. Evidence submitted under previous NOA's

A. DRAWINGS “Submitted under NOA # 15-0304.02”

1. Drawing No. **00-18**, titled “Sectional Garage Door”, sheets 1 through 5 of 5, dated 08/24/2000, with last revision **I** dated 03/09/2015, prepared by Al-Farooq Corporation, signed and sealed by Javad Ahmad, P.E.

B. TESTS “Submitted under NOA # 09-0128.03”

1. Test report of Tensile Test per ASTM E 8, Report No. **HETI 08-T182**, along with marked-up drawings and installation diagram of a DAB 824 24 GA Sectional Garage Door with Fixed Windows prepared by Hurricane Engineering & Testing, Inc., dated 12/23/2008, signed and sealed by Candido F. Font, P.E.

“Submitted under NOA # 08-1106.05”

2. Test reports on 1) Uniform Static Air Pressure Test Loading per FBC TAS 202-94
2) Large Missile Impact Test per FBC, TAS 201-94
3) Cyclic Wind Pressure Loading per FBC, TAS 203-94
4) Forced Entry Test per FBC 2411 3.2.1, TAS 202-94
along with marked-up drawings and installation diagram of a DAB 824 24 GA Sectional Garage Door with Fixed Windows, prepared by Hurricane Engineering & Testing, Inc, Test Reports No. **HETI-08-2149A/B**, dated 06/27/2008, signed and sealed by Candido F. Font, P.E.

“Submitted under NOA # 00-1121.01”

3. Test report of Uniform Static Air Pressure and Force Entry Resistance Test, per FBC, TAS 202-94 on “Sectional Residential Garage Doors”, prepared by Hurricane Engineering & Testing, Inc., Report No. **HETI 00-903**, dated 08/11/2000, signed and sealed by Hector M. Medina, P.E.
4. Test report of Large Missile Impact Test, per FBC, TAS 201-94 and Cyclic Wind Pressure Test per, per FBC, TAS 203-94 on “Sectional Residential Garage Doors”, prepared by Hurricane Engineering & Testing, Inc., Report No. **HETI 00-904**, dated 08/17/2000, signed and sealed by Hector M. Medina, P.E.
5. Test report on Salt Spray (Corrosion) Test per ASTM B 117 of a painted G-40 steel panels, prepared by Celotex Corporation, Test Report No. **258592**, dated 08/17/1998, signed by W. A. Jackson, P.E. **“Submitted under NOA # 03-0210.04”**

C. CALCULATIONS “Submitted under NOA # 14-0814.05”

1. Anchor verification calculations prepared by Al-Farooq Corporation, dated 09/22/2014 and 07/24/2014, signed and sealed by Javad Ahmad, P.E.
2. Anchor verification calculations prepared by Al-Farooq Corporation, complying with F.B.C 2007, dated 12/19/2008, signed and sealed by Humayoun Farooq, P.E.
“Submitted under NOA # 09-0128.03”



Helmy A. Makar, P.E., M.S.
Product Control Section Supervisor
NOA No. 23-0710.18
Expiration Date: 02/22/2025
Approval Date: 08/10/2023

NOTICE OF ACCEPTANCE: EVIDENCE SUBMITTED

D. QUALITY ASSURANCE

1. Miami-Dade Department of Regulatory and Economic Resources (RER)

E. MATERIAL CERTIFICATIONS

1. Notice of Acceptance No. **13-0717.01**, issued to SABIC Innovative Plastics, for their Lexan Sheet Products, approved on 11/28/2013 and expiring on 07/17/2018.
2. Notice of Acceptance No. **14-0311.08**, issued to Insulfoam, LLC, for their Insulfoam Expanded Polystyrene Insulation, approved on 08/14/2014 and expiring on 11/29/2017.
3. Notice of Acceptance No. **11-0926.07**, issued to Dyplast Products, LLC, for their Expanded Polystyrene Block Type Insulation, approved on 11/10/2011 and expiring on 01/11/2017.
4. Notice of Acceptance No. **11-0926.06**, issued to Dyplast Products, LLC, for their Dyplast ISO-C1 Polyisocyanurate Insulation, approved on 11/10/2011 and expiring on 01/11/2017.
5. Notice of Acceptance No. **10-1129.04**, issued to Cellofoam North America Inc, for their Expanded Polystyrene Block Insulation, approved on 02/24/2011 and expiring on 02/24/2016.

“Submitted under NOA # 05-0228.02”

6. Test Report on Accelerated Weathering Using Xenon Arc Light Apparatus Test per ASTM G155 of “PVC Extrusion Material”, prepared by Hurricane Engineering & Testing, Inc., Report No. **HETI 04-A002**, dated 09/27/2004, signed and sealed by Rafael E. Droz-Seda, P.E.
7. Test Reports on Tensile Test per ASTM D638 of “PVC Extrusion Material”, prepared by Hurricane Engineering & Testing Inc., Report No. **HETI 04-T251**, dated 11/29/2004 signed and sealed by I. Ghia, P.E.
8. Test Report on Self-Ignition Temperature Test, Rate of Burn Test and Smoke Density Test of “REHAU non-foam PVC extrusion material”, prepared by ETC Laboratories, Report No. **04-761-15019.0**, dated 05/06/2004, signed and sealed by J. L. Doldan, P.E.

F. STATEMENTS *“Submitted under NOA # 14-0814.05”*

1. Statement letter of code conformance to the 5th edition (2014) FBC and of no financial interest, issued by Al-Farooq Corporation, dated 05/13/2014, signed and sealed by Javad Ahmad, P.E.

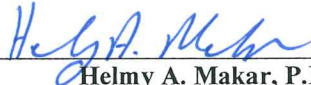

Helmy A. Makar, P.E., M.S.
Product Control Section Supervisor
NOA No. 23-0710.18
Expiration Date: 02/22/2025
Approval Date: 08/10/2023

NOTICE OF ACCEPTANCE: EVIDENCE SUBMITTED

2. EVIDENCE SUBMITTED UNDER PREVIOUS NOA # 19-1105.05

A. DRAWINGS “Submitted under NOA #17-1108.30”

1. Drawing No. **00-18**, titled “Sectional Garage Door”, sheets 1 through 5 of 5, dated 08/24/2000, with last revision **J** dated 10/31/2017, prepared by Al-Farooq Corporation, signed and sealed by Javad Ahmad, P.E.

B. TESTS

1. None.

C. CALCULATIONS

1. None.

D. QUALITY ASSURANCE

1. Miami-Dade Department of Regulatory and Economic Resources (RER)

E. MATERIAL CERTIFICATIONS

1. Notice of Acceptance No. **15-0915.08** issued to **Sabic Innovative Plastic, US, LLC** for their “**LEXAN® Polycarbonate Sheet Products**” dated 12/10/15, expiring on 07/17/18.
2. Notice of Acceptance No. **17-0221.06**, issued to Insulfoam, LLC, a Div. of Carlisle Const. Materials, for their Insulfoam Expanded Polystyrene Insulation, approved on 06/01/2017 and expiring on 11/29/2022.
3. Notice of Acceptance No. **16-1129.05**, issued to Dyplast Products, LLC, for their Expanded Polystyrene Block Type Insulation, approved on 01/19/2017 and expiring on 01/11/2022.
4. Notice of Acceptance No. **16-1108.04**, issued to Dyplast Products, LLC, for their Dyplast ISO-C1 Polyisocyanurate Insulation, approved on 01/19/2017 and expiring on 01/11/2022.
5. Notice of Acceptance No. **15-1203.04**, issued to Cellofoam North America, Inc., for their Expanded Polystyrene Block Insulation, approved on 03/17/2016 and expiring on 02/24/2021.

F. STATEMENTS

1. Statement letter of code conformance to the 6th Edition (2017) FBC prepared by Al-Farooq Corporation, dated 10/31/2019, signed and sealed by Javad Ahmad, P.E.



Helmy A. Makar, P.E., M.S.
Product Control Section Supervisor
NOA No. 23-0710.18
Expiration Date: 02/22/2025
Approval Date: 08/10/2023

NOTICE OF ACCEPTANCE: EVIDENCE SUBMITTED

3. EVIDENCE SUBMITTED UNDER PREVIOUS NOA # 20-0929.12

A. DRAWINGS

1. Drawing No. **00-18**, titled "Sectional Garage Door", sheets 1 through 5 of 5, dated 08/24/2000, with last revision **J** dated 10/31/2017, prepared by Al-Farooq Corporation, signed and sealed by Jalal Farooq, P.E. on 12/02/2020.

B. TESTS

1. None.

C. CALCULATIONS

1. None.

D. QUALITY ASSURANCE

1. Miami-Dade Department of Regulatory and Economic Resources (RER)

E. MATERIAL CERTIFICATIONS

1. None.

F. STATEMENTS

1. Conformance Letter to the 6th edition (2017) and 7th edition (2020) FBC and of no financial interest issued by Al-Farooq Corporation, dated 07/15/2020, signed and sealed by Jalal Farooq, P.E.

4. NEW EVIDENCE SUBMITTED

A. DRAWINGS

1. Drawing No. **00-18**, titled "Sectional Garage Door", sheets 1 through 5 of 5, dated 08/24/2000, with last revision **K** dated 06/19/2023, prepared by Al-Farooq Corporation, signed and sealed by Jalal Farooq, P.E. on 06/22/2023.

B. TESTS

1. None.

C. CALCULATIONS

1. None.

D. QUALITY ASSURANCE

1. Miami-Dade Department of Regulatory and Economic Resources (RER)

E. MATERIAL CERTIFICATIONS

1. None.

F. STATEMENTS

1. Conformance Letter to the 8th edition (2023) and 7th edition (2020) FBC and of no financial interest issued by Al-Farooq Corporation, dated 06/20/2023, signed and sealed by Jalal Farooq, P.E.



Helmy A. Makar, P.E., M.S.
Product Control Section Supervisor
NOA No. 23-0710.18
Expiration Date: 02/22/2025
Approval Date: 08/10/2023

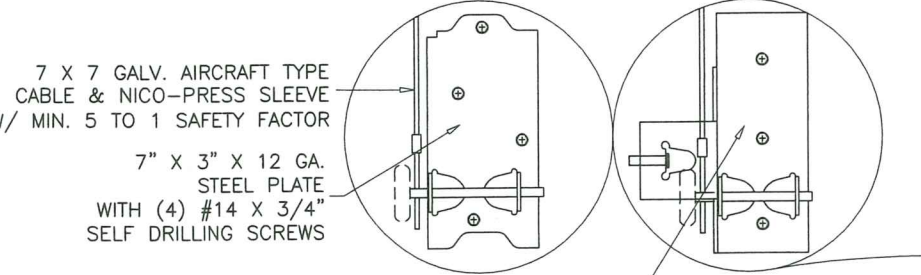
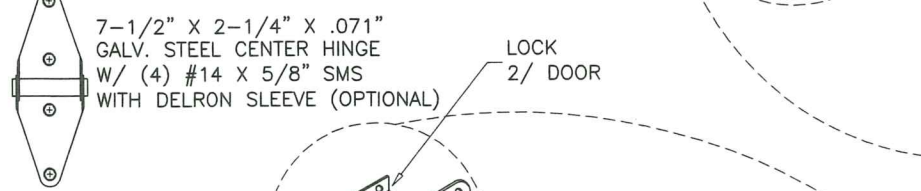
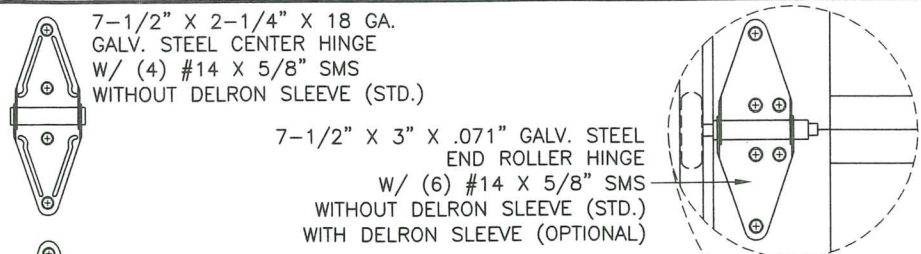

DOOR HEIGHT	CONSISTS OF		TOTAL # OF 'U' BARS AT EACH DOOR
6'-6"	2 SECTIONS 18"	2 SECTIONS 21"	8
6'-9"	1 SECTION 18"	3 SECTIONS 21"	
7'	4 SECTIONS 21"	-	
7'-6"	5 SECTIONS 18"	-	
7'-9"	4 SECTIONS 18"	1 SECTION 21"	10
8'	3 SECTIONS 18"	2 SECTIONS 21"	
8'-3"	2 SECTIONS 18"	3 SECTIONS 21"	
8'-6"	1 SECTION 18"	4 SECTIONS 21"	
8'-9"	5 SECTIONS 21"	-	12
9'	6 SECTIONS 18"	-	
9'-3"	5 SECTIONS 18"	1 SECTION 21"	
9'-6"	4 SECTIONS 18"	2 SECTIONS 21"	
9'-9"	3 SECTIONS 18"	3 SECTIONS 21"	14
10'	2 SECTIONS 18"	4 SECTIONS 21"	
10'-3"	1 SECTION 18"	5 SECTIONS 21"	
10'-6"	6 SECTIONS 21"	-	
10'-9"	6 SECTIONS 18"	1 SECTION 21"	16
11'	5 SECTIONS 18"	2 SECTIONS 21"	
11'-3"	4 SECTIONS 18"	3 SECTIONS 21"	
11'-6"	3 SECTIONS 18"	4 SECTIONS 21"	
11'-9"	2 SECTIONS 18"	5 SECTIONS 21"	18
12'	1 SECTIONS 18"	6 SECTIONS 21"	
12'-3"	7 SECTIONS 21"	-	
12'-6"	6 SECTIONS 18"	2 SECTIONS 21"	
12'-9"	5 SECTIONS 18"	3 SECTIONS 21"	20
13'	4 SECTIONS 18"	4 SECTIONS 21"	
13'-3"	3 SECTIONS 18"	5 SECTIONS 21"	
13'-6"	2 SECTIONS 18"	6 SECTIONS 21"	
13'-9"	1 SECTION 18"	7 SECTIONS 21"	18
14'	8 SECTIONS 21"	-	
14'-3"	6 SECTIONS 18"	3 SECTIONS 21"	
14'-6"	5 SECTIONS 18"	4 SECTIONS 21"	
14'-9"	4 SECTIONS 18"	5 SECTIONS 21"	18
15'	3 SECTIONS 18"	6 SECTIONS 21"	
15'-3"	2 SECTIONS 18"	7 SECTIONS 21"	
15'-6"	1 SECTION 18"	8 SECTIONS 21"	
15'-9"	9 SECTIONS 21"	-	20
16'	6 SECTIONS 18"	4 SECTIONS 21"	

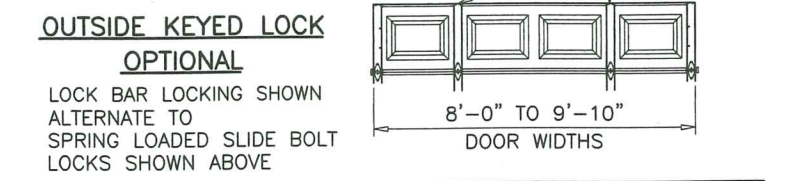
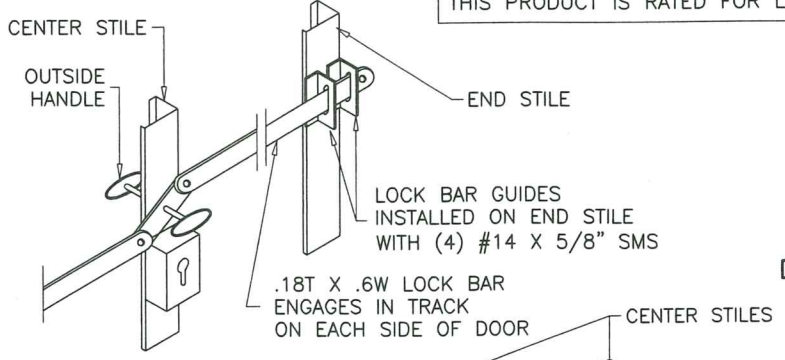

PRODUCT REVISED
 as complying with the Florida Building Code
 Acceptance No 23-0710.18
 Expiration Date 02/22/2025
 By *Heba A. M. Al...*
 Miami Code Product Control

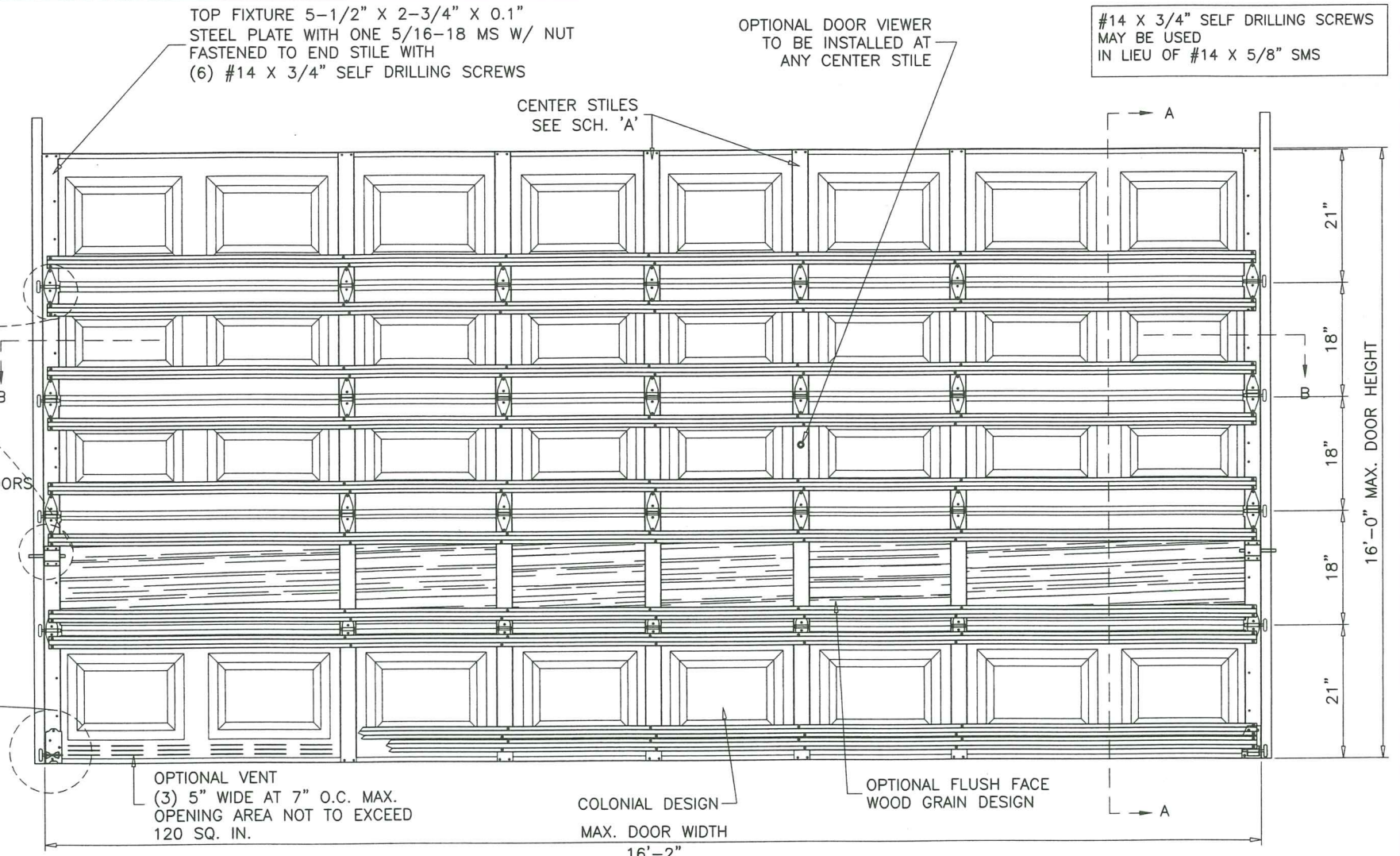

THIS PRODUCT IS RATED FOR LARGE MISSILE IMPACT

INSIDE ELEVATION
 RAISED PANEL EMBOSSED DOOR

DOOR TESTED IN ACCORDANCE WITH THE REQUIREMENTS OF FLORIDA BUILDING CODE, TAS-202, TAS-201 & TAS-203 FOR HVHZ AND ASTM E1886-05/ASTM E1996-09.

DAB DOORS INC.
 Hurricane Master® Model 824/811
 Max. Size 16'-2" X 16'-0" High
 With Window Lite Option

DESIGN PRESSURE RATING = + 56.0 PSF
 - 64.0 PSF

SCHEDULE 'A'

CENTER STILES CONFIGURATION	
DOOR WIDTHS	# OF CENTER STILES
8'-0" TO 9'-10"	2
10'-0" TO 11'-10"	2
12'-0" TO 13'-10"	3
14'-0" TO 15'-10"	4
15'-11" TO 16'-10"	5

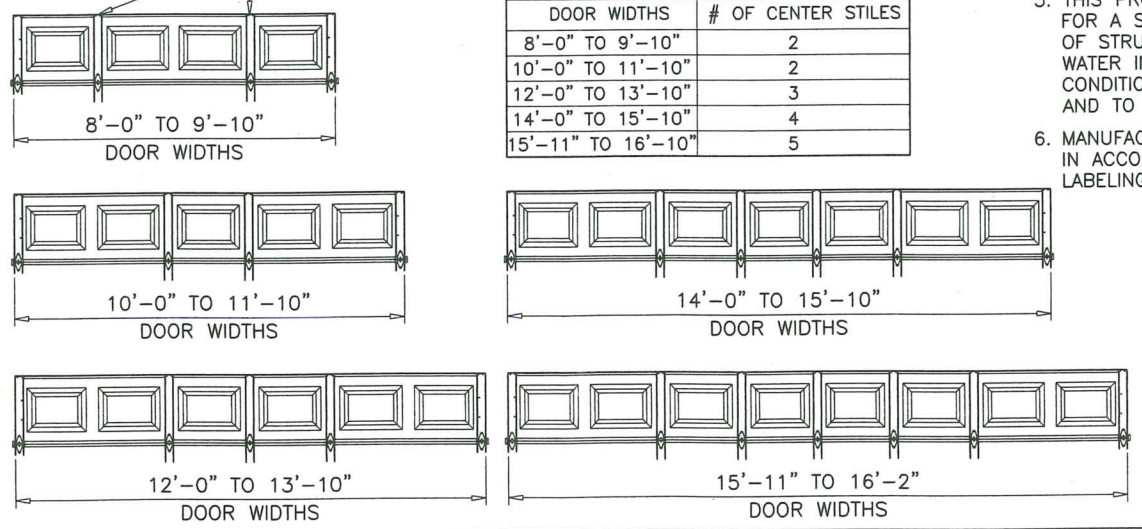

- GENERAL NOTES**
- THIS PRODUCT HAS BEEN DESIGNED AND TESTED TO COMPLY WITH THE REQUIREMENTS OF THE 2020 (7TH EDITION)/2023 (8TH EDITION) FLORIDA BUILDING CODE INCLUDING HIGH VELOCITY HURRICANE ZONE (HVHZ).
 - ANCHORS SHALL BE CORROSION RESISTANT, SPACED AS SHOWN ON DETAILS AND INSTALLED PER MANUF'S INSTRUCTIONS. SPECIFIED EMBEDMENT TO BASE MATERIAL SHALL BE BEYOND WALL DRESSING OR STUCCO.
 - A LOAD DURATION INCREASE IS USED IN DESIGN OF ANCHORS INTO WOOD ONLY.
 - MATERIALS INCLUDING BUT NOT LIMITED TO STEEL/METAL SCREWS, THAT COME INTO CONTACT WITH OTHER DISSIMILAR MATERIALS SHALL MEET THE REQUIREMENTS OF THE 2020/2023 FLORIDA BLDG. CODE & ADOPTED STANDARDS.
 - THIS PRODUCT APPROVAL IS GENERIC AND DOES NOT PROVIDE INFORMATION FOR A SITE SPECIFIC PROJECT, i.e. LIFE SAFETY OF THIS PRODUCT, ADEQUACY OF STRUCTURE RECEIVING THIS PRODUCT AND SEALING AROUND OPENING FOR WATER INFILTRATION RESISTANCE ETC. CONDITIONS NOT SHOWN IN THIS DRAWING ARE TO BE ANALYZED SEPARATELY, AND TO BE REVIEWED BY BUILDING OFFICIAL.
 - MANUFACTURER'S LABEL SHALL BE LOCATED ON A READILY VISIBLE LOCATION IN ACCORDANCE WITH SECTION 1709.9.3 OF FLORIDA BUILDING CODE. LABELING TO COMPLY WITH SECTION 1709.9.2.

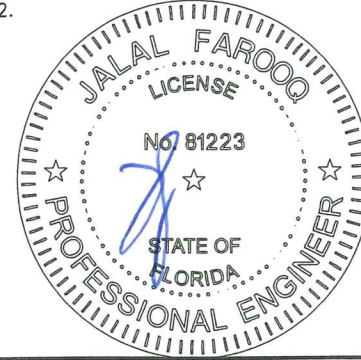

JUN 22 2023

AL-FAROOQ CORPORATION
 ENGINEERS & PRODUCT DEVELOPMENT
 9360 SUNSET DRIVE, SUITE 220
 MIAMI, FLORIDA 33173 (C.A.N. 3538)
 TEL. (305) 264-8100 FAX. (305) 262-6978

SECTIONAL GARAGE DOOR
DAB Door Company, Inc.
 12193 N.W. 98th Ave.
 Hialeah Gardens, FL 33018
 Tel: (800) 257-2016 Fax: (305) 362-9272

revisions:

no	date	description
G	09.16.14	NO CHANGE THIS SHEET
H	11.03.14	NO CHANGE THIS SHEET
I	03.09.15	UPDATED TO 2017 FBC
J	10.31.17	UPDATED TO 2023 FBC
K	06.19.23	UPDATED TO 2023 FBC

date: 08-24-00
 scale: 1/2"=1'-0"
 dr. by: TARIQ
 chk. by:
 drawing no. 00-18
 sheet 1 of 5

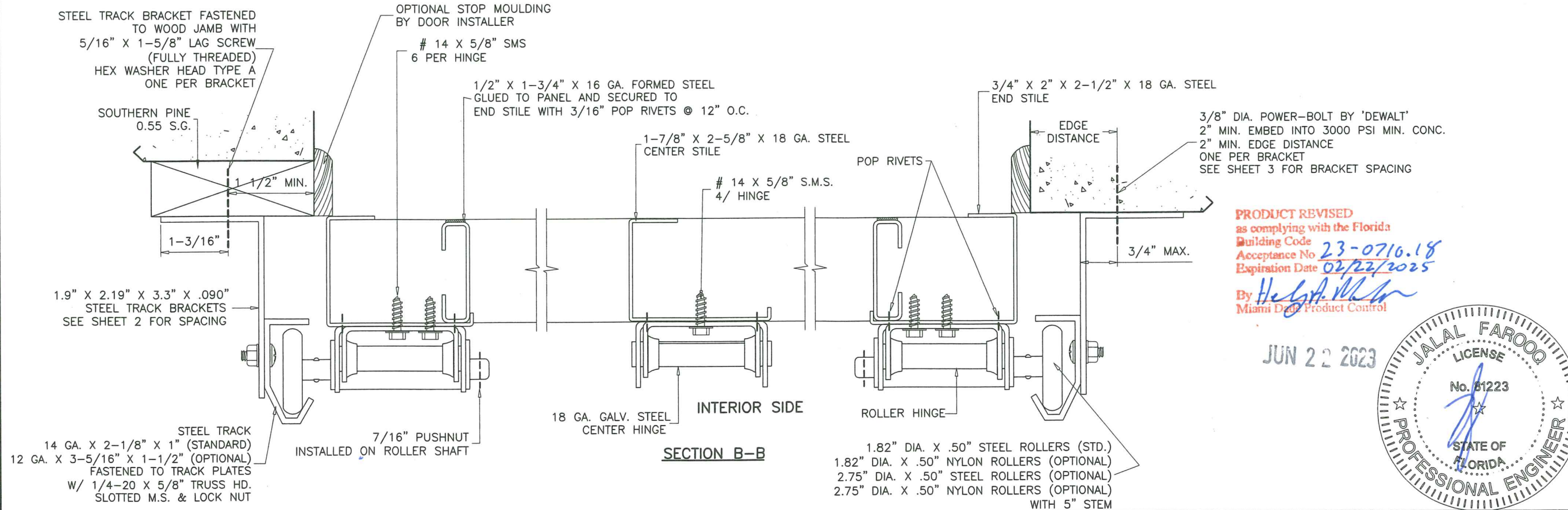
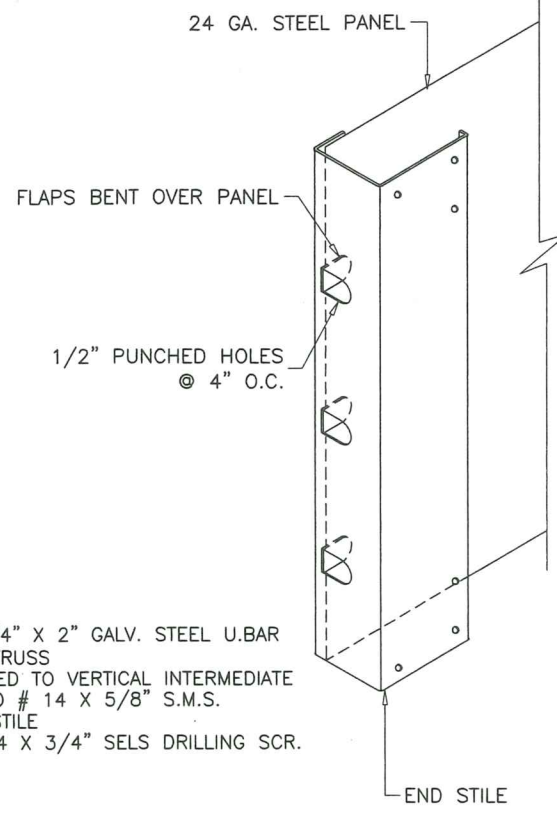
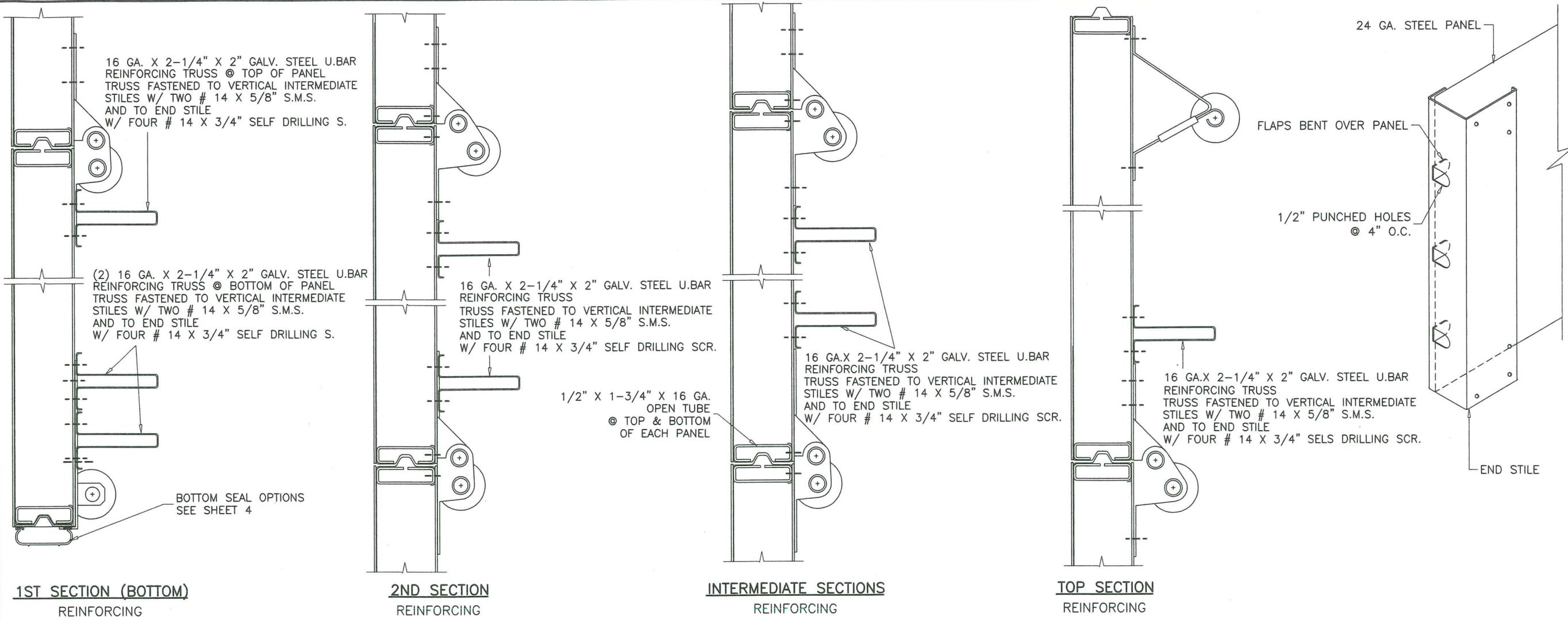

PRODUCT REVISED
 as complying with the Florida
 Building Code
 Acceptance No. 23-0716.18
 Expiration Date 02/22/2025
 By *Healy Product Control*
 Miami Door Product Control

JUN 22 2023



af c
AL-FAROOQ CORPORATION
 ENGINEERS & PRODUCT DEVELOPMENT
 9360 SUNSET DRIVE, SUITE 220
 MIAMI, FLORIDA 33173 (C.A.N. 3538)
 TEL. (305) 264-8100 FAX. (305) 262-6978

SECTIONAL GARAGE DOOR
DAB Door Company, Inc.
 12193 N.W. 98th Ave.
 Hialeah Gardens, FL 33018
 Tel: (800) 257-2016 Fax: (305) 362-9272

no.	date	description
G	09.16.14	NO CHANGE THIS SHEET
H	11.03.14	NO CHANGE THIS SHEET
I	03.09.15	BOTTOM SEAL OPTION ADDED
J	10.31.17	UPDATED TO 2017 FBC
K	06.19.23	UPDATED TO 2023 FBC

date: 08-24-00
 scale: -
 dr. by: TARIQ
 chk. by:
 drawing no.
00-18
 sheet 2 of 5

GARAGE\00-18DAB

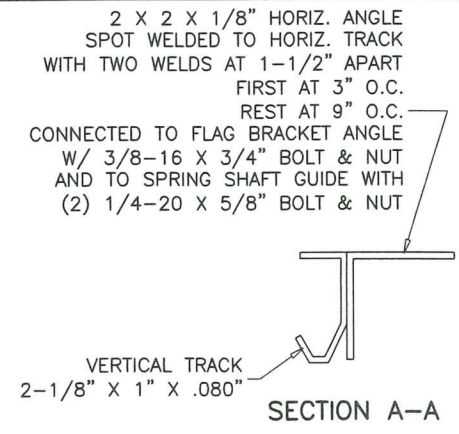
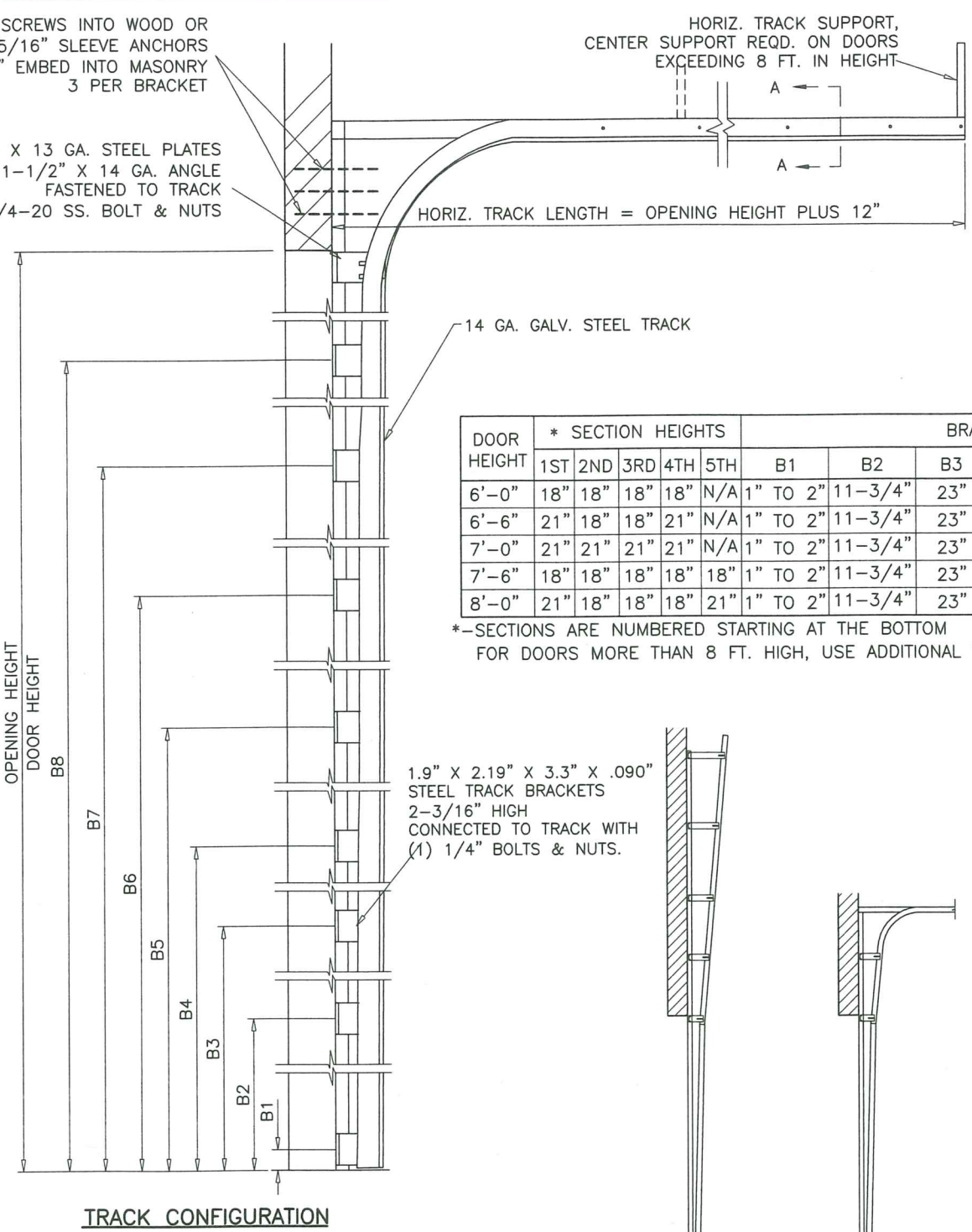
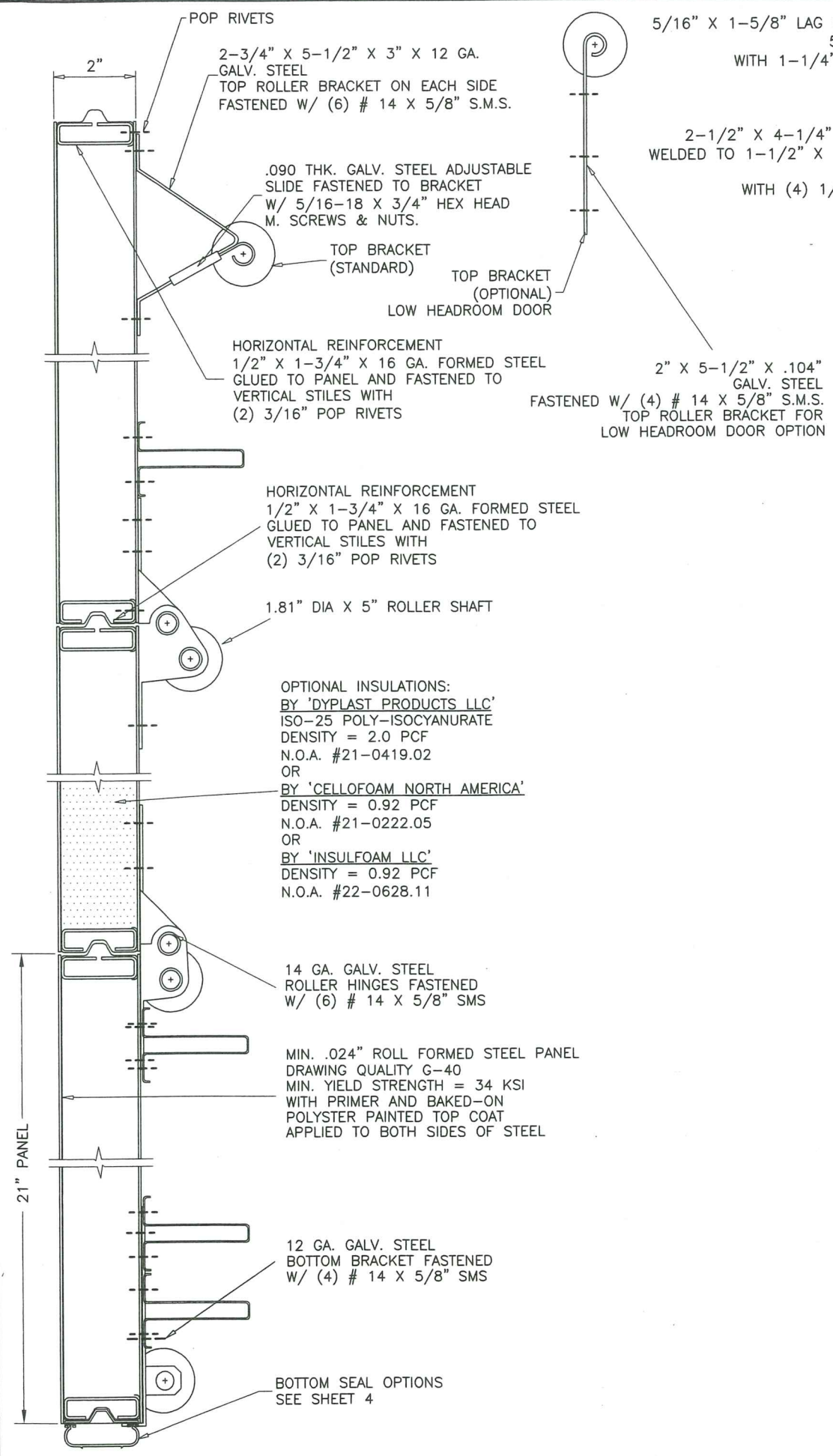

DOOR HEIGHT	* SECTION HEIGHTS					BRACKET PLACEMENTS							
	1ST	2ND	3RD	4TH	5TH	B1	B2	B3	B4	B5	B6	B7	B8
6'-0"	18"	18"	18"	18"	N/A	1" TO 2"	11-3/4"	23"	34"	45"	56"	67"	-
6'-6"	21"	18"	18"	21"	N/A	1" TO 2"	11-3/4"	23"	34"	45"	56"	67"	-
7'-0"	21"	21"	21"	21"	N/A	1" TO 2"	11-3/4"	23"	34"	45"	56"	67"	-
7'-6"	18"	18"	18"	18"	18"	1" TO 2"	11-3/4"	23"	34"	45"	56"	67"	78-1/4"
8'-0"	21"	18"	18"	18"	21"	1" TO 2"	11-3/4"	23"	34"	45"	56"	67"	78-1/4"

*-SECTIONS ARE NUMBERED STARTING AT THE BOTTOM FOR DOORS MORE THAN 8 FT. HIGH, USE ADDITIONAL TRACK BRACKETS AT 10" O.C.

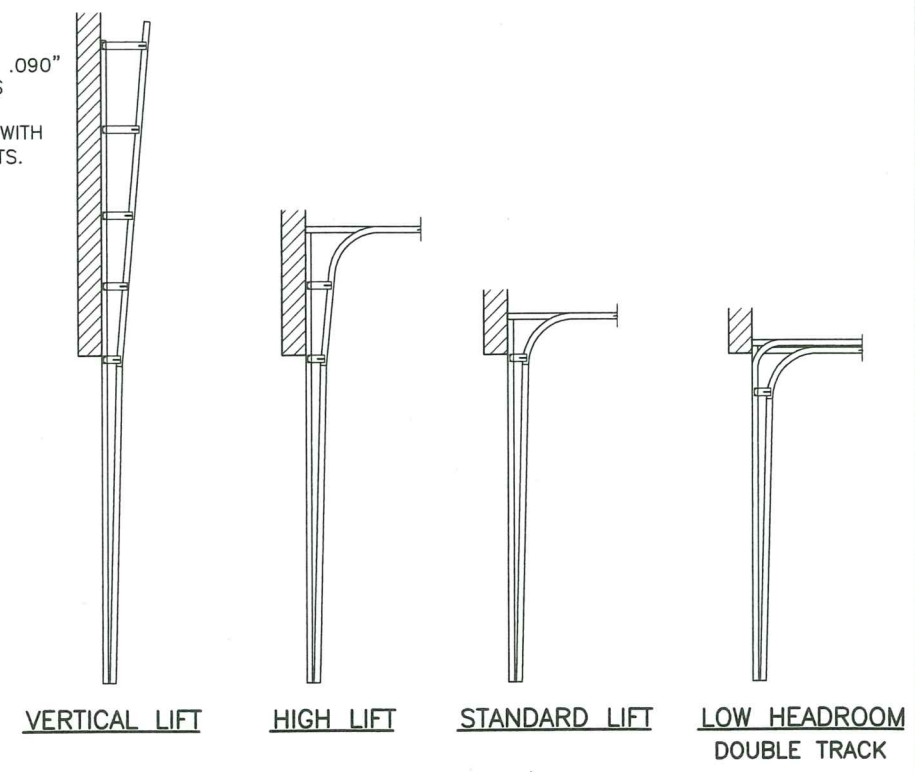

PRODUCT REVISED as complying with the Florida Building Code
 Acceptance No 23-0710.18
 Expiration Date 02/22/2025
 By Hely A. M...
 Miami Door Product Control

JUN 22 2023

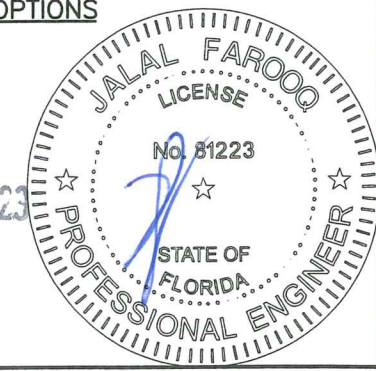

AL-FAROOQ CORPORATION
 ENGINEERS & PRODUCT DEVELOPMENT
 9360 SUNSET DRIVE, SUITE 220
 MIAMI, FLORIDA 33173
 TEL. (305) 264-8100 FAX. (305) 262-6978
 GARAGE\00-18DAB

SECTIONAL GARAGE DOOR
DAB Door Company, Inc.
 12193 N.W. 98th Ave.
 Hialeah Gardens, Fl. 33018
 Tel: (800) 257-2016 Fax: (305) 362-9272

no	date	description
G	09.16.14	FOAM NOA REV.
H	11.03.14	NO CHANGE THIS SHEET
I	03.09.15	BOTTOM SEAL OPTION ADDED
J	10.31.17	UPDATED TO 2017 FBC
K	06.19.23	UPDATED TO 2023 FBC

date: 08-24-00
 scale: -
 dr. by: TARIQ
 chk. by:

drawing no.
00-18
 sheet 3 of 5

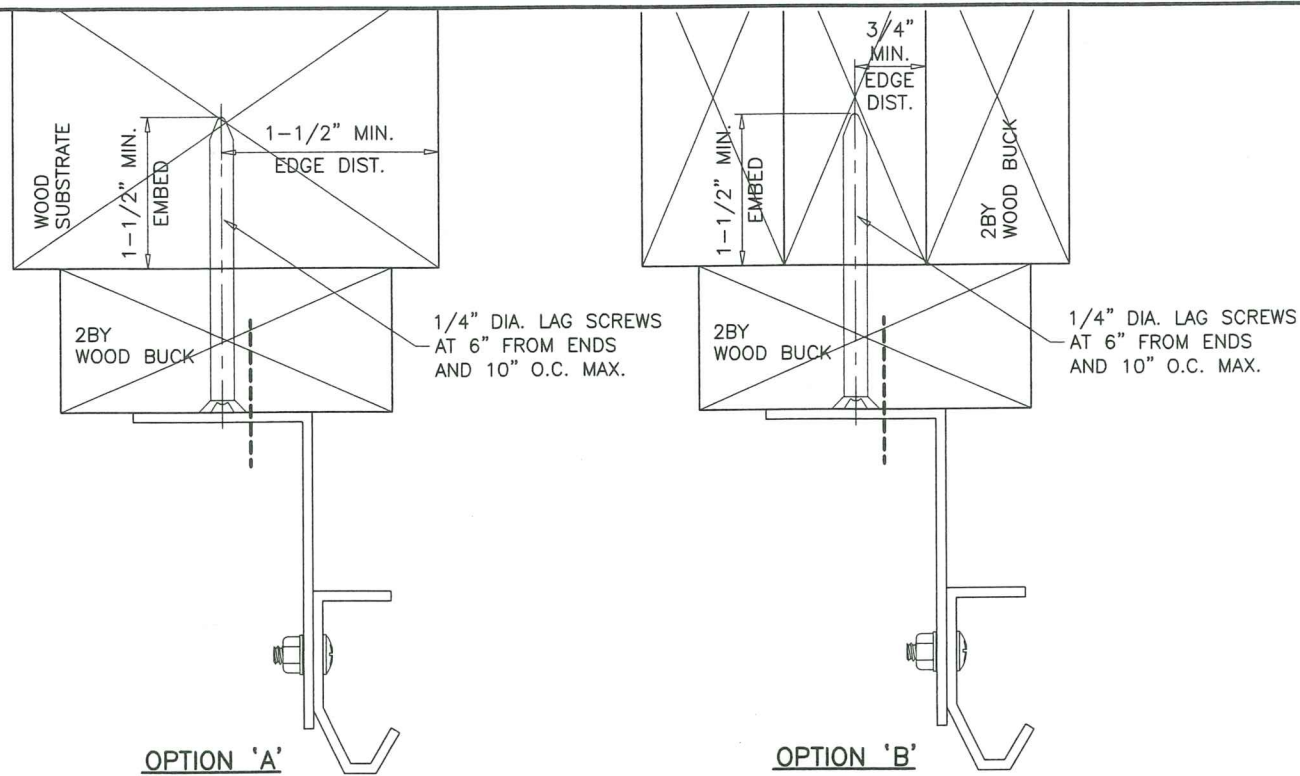

WOOD BUCK CONNECTION TO WOOD SUBSTRATE (WOOD SPECIFIC GRAVITY SG=0.55 MIN.)

THE INSTALLATION METHODS SHOWN ABOVE SHOWS 2X6 SYP WOOD BUCK ATTACHMENT TO WOOD STRUCTURES. IF THESE METHODS ARE FOLLOWED NO ADDITIONAL CALCULATIONS/DESIGN WILL BE REQUIRED FOR DESIGN OF GARAGE DOOR ANCHORAGE. FOR DOOR REPLACEMENT APPLICATIONS WITH NO ENGINEER OF RECORD, INSTALLATION MAY BE VERIFIED AND APPROVED BY THE BUILDING OFFICIAL UPON INSPECTION.

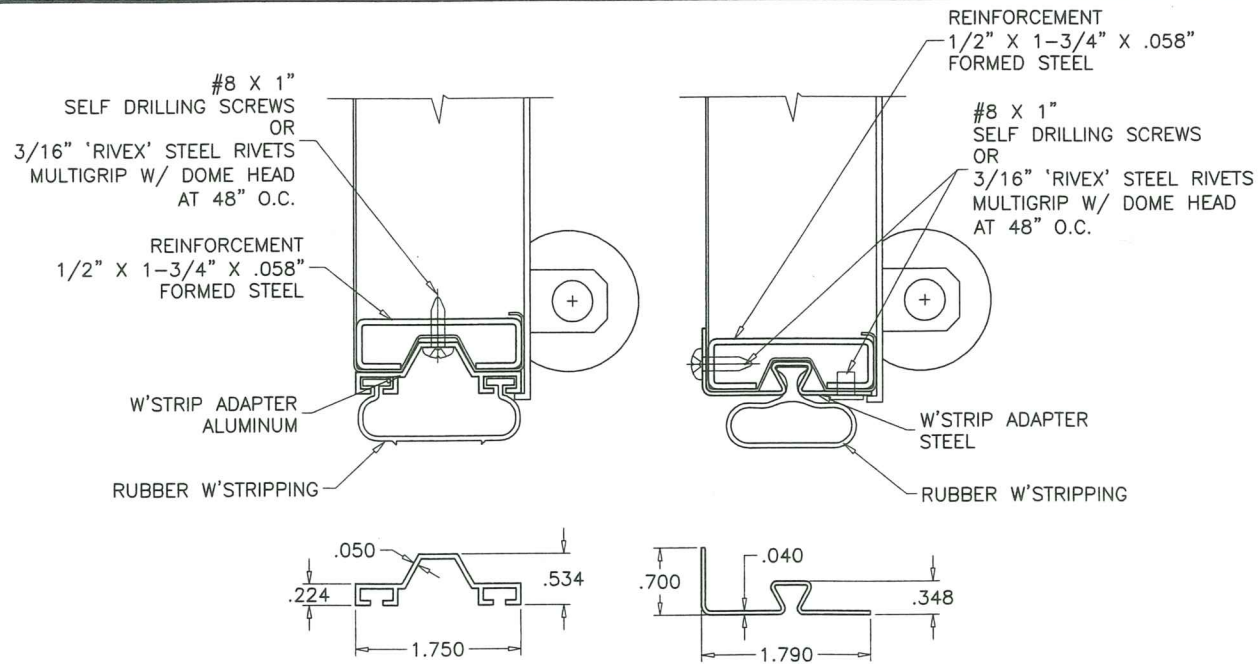

BOTTOM SEAL OPTIONS

WOOD BUCK CONNECTION TO MASONRY

PRESSURE TREATED 2X6 SYP WOOD JAMBS WHICH SHALL BE ANCHORED TO GROUTED REINFORCED MASONRY BLOCK WALL OR CONC. COLUMN WITH

1/4" ULTRACON+ BY 'DEWALT' WITH SPACING OF 8" O.C. INTO GROUT FILLED BLOCK WALL, WITH 2-1/4" MIN. EMBED 8" O.C. INTO 3000 PSI CONCRETE, WITH 1-3/4" MIN. EMBED 2-1/2" MIN. EDGE DISTANCE

1/4" TAPPER BY 'DEWALT' WITH SPACING OF 7" O.C. INTO GROUT FILLED BLOCK WALL, WITH 1-1/2" MIN. EMBED 8" O.C. INTO 3000 PSI CONCRETE, WITH 1-3/4" MIN. EMBED 3" MIN. EDGE DISTANCE

3/8" CONFLEX BY 'ELCO' 8" O.C. INTO GROUT FILLED BLOCK WALL, WITH 2" MIN. EMBED 8" O.C. INTO 3000 PSI CONCRETE, WITH 1-3/4" MIN. EMBED 3-3/4" MIN. EDGE DISTANCE

3/8" LDT BY 'ITW' WITH SPACING OF 18" O.C. INTO 3000 PSI CONCRETE, WITH 2-1/2" MIN. EMBED 3" MIN. EDGE DISTANCE

3/8" HLC SLEEVE BY 'HILTI' WITH SPACING OF 9" O.C. INTO 3000 PSI CONCRETE, WITH 1-1/4" MIN. EMBED AND 2-1/2" MIN. EDGE DISTANCE

PREPARATION OF JAMBS BY OTHERS

FOR NEW CONSTRUCTION ENGINEER OF RECORD OR ARCHITECT TO VERIFY ADEQUACY OF SUPPORTING STRUCTURE TO SUPPORT LOADS IMPOSED BY DOOR SYSTEM. FOR DOOR REPLACEMENT IN RETROFIT BUILDINGS WITH NO ENGINEER OF RECORD, DOOR INSTALLATION MAY BE REVIEWED AND APPROVED BY BUILDING OFFICIAL UPON INSPECTION.

MAXIMUM EXTERIOR(+) LOAD PER JAMB = (16.16' X 56 PSF)/2 = 452.5 Lbs per Ft.
 MAXIMUM INTERIOR(-) LOAD PER JAMB = (16.16' X 64 PSF)/2 = 517.1 Lbs per Ft.

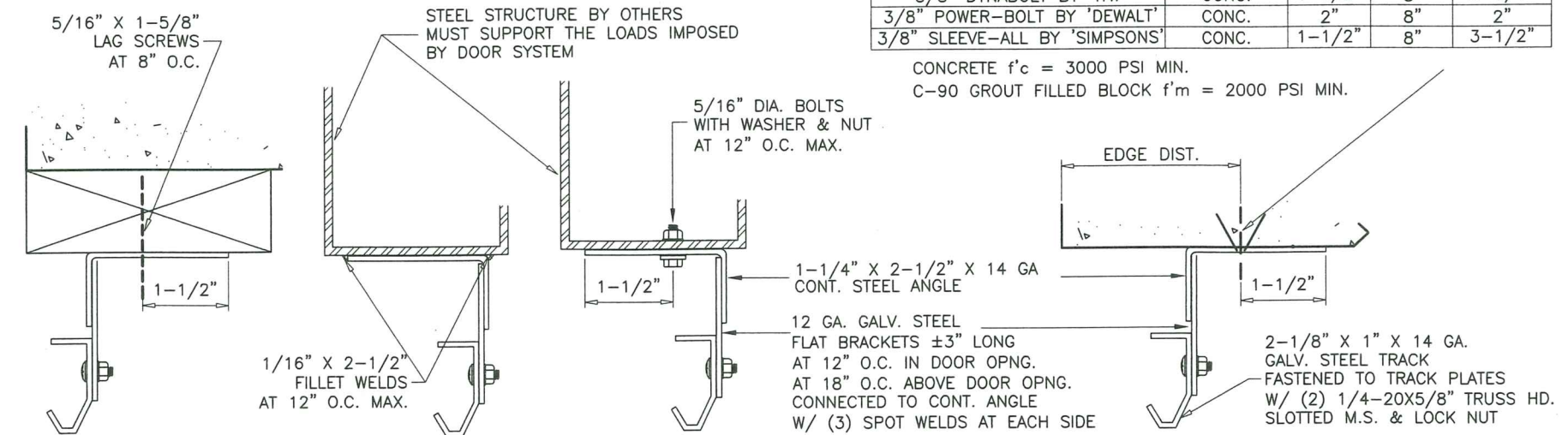

ALTERNATE TRACK INSTALLATION

ANCHOR SPACING				
ANCHORS	STRUCTURE	EMBED	SPACING	EDGE DIST.
3/8" HLC SLEEVE BY 'HILTI'	CONC.	1-1/4"	8"	3"
3/8" CONFLEX BY 'ELCO'	FILLED BLOCK	2"	8"	3-3/4"
3/8" DYNABOLT BY 'ITW'	CONC.	1-1/2"	8"	3-3/4"
3/8" POWER-BOLT BY 'DEWALT'	CONC.	2"	8"	2"
3/8" SLEEVE-ALL BY 'SIMPSONS'	CONC.	1-1/2"	8"	3-1/2"

CONCRETE f'c = 3000 PSI MIN.
 C-90 GROUT FILLED BLOCK f'm = 2000 PSI MIN.

AL-FAROOQ CORPORATION
 ENGINEERS & PRODUCT DEVELOPMENT
 9360 SUNSET DRIVE, SUITE 220
 MIAMI, FLORIDA 33173 (C.A.N. 3538)
 TEL. (305) 264-8100 FAX. (305) 262-6978

SECTIONAL GARAGE DOOR
DAB Door Company, Inc.
 12193 N.W. 98th Ave.
 Hialeah Gardens, FL 33018
 Tel: (800) 257-2016 Fax: (305) 362-9272

revisions:	no	date	description
	G	09.16.14	ANCHORS REVISED
	H	11.03.14	REV. PER RER COMMENTS
	I	03.09.15	BOTTOM SEAL OPTION ADDED
	J	10.31.17	UPDATED TO 2017 FBC
	K	06.19.23	UPDATED TO 2023 FBC

date: 08-24-00	scale: -	dr. by: TARIQ	chk. by:
----------------	----------	---------------	----------

drawing no. **00-18**
 sheet 4 of 5

PRODUCT REVISED
 as complying with the Florida
 Building Code
 Acceptance No. 23-0710.18
 Expiration Date 02/22/2025
 By: *Helga A. Walker*
 Miami Dist. Product Control

JUN 22 2023

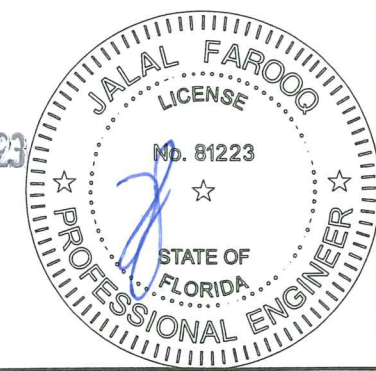

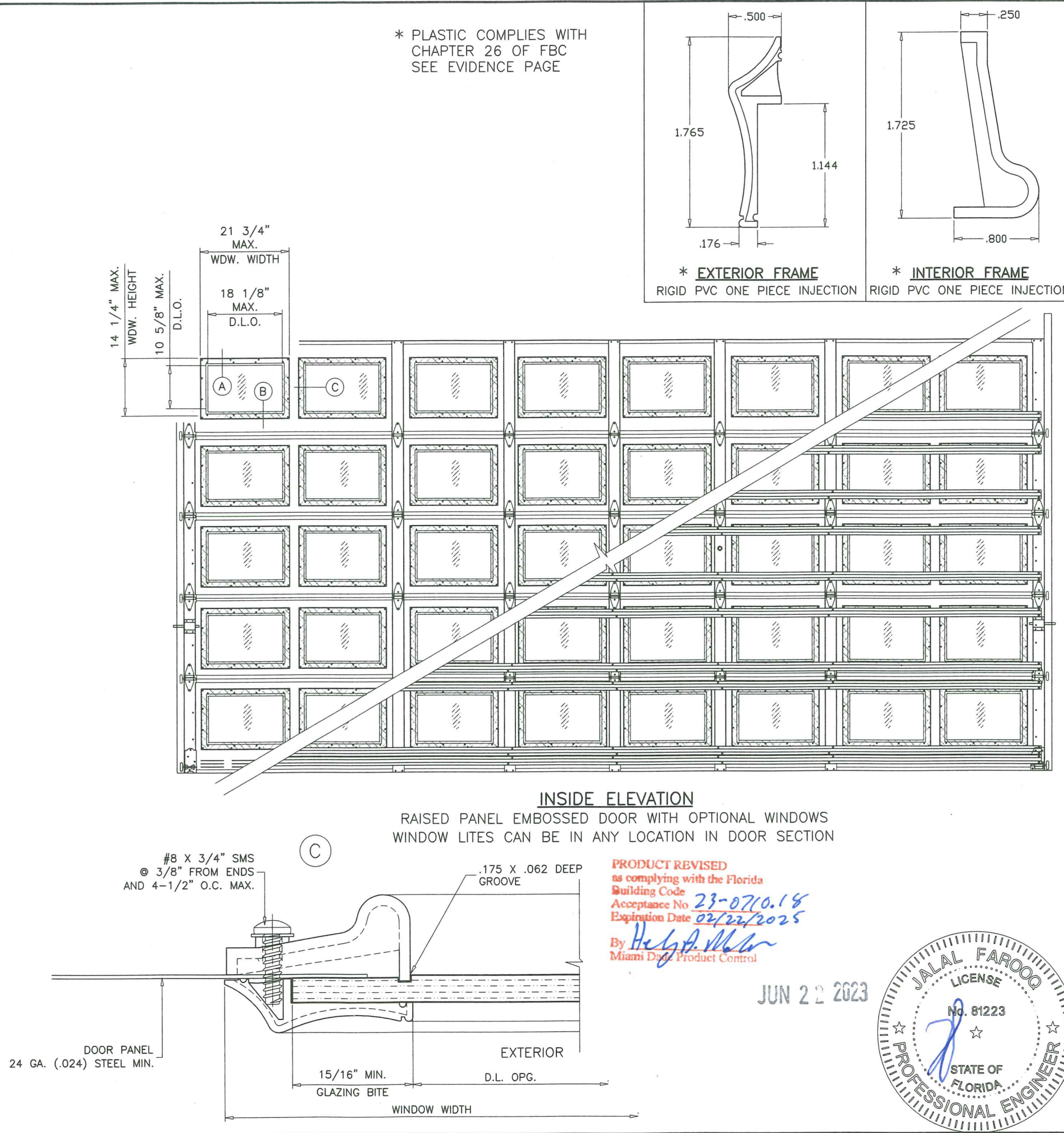
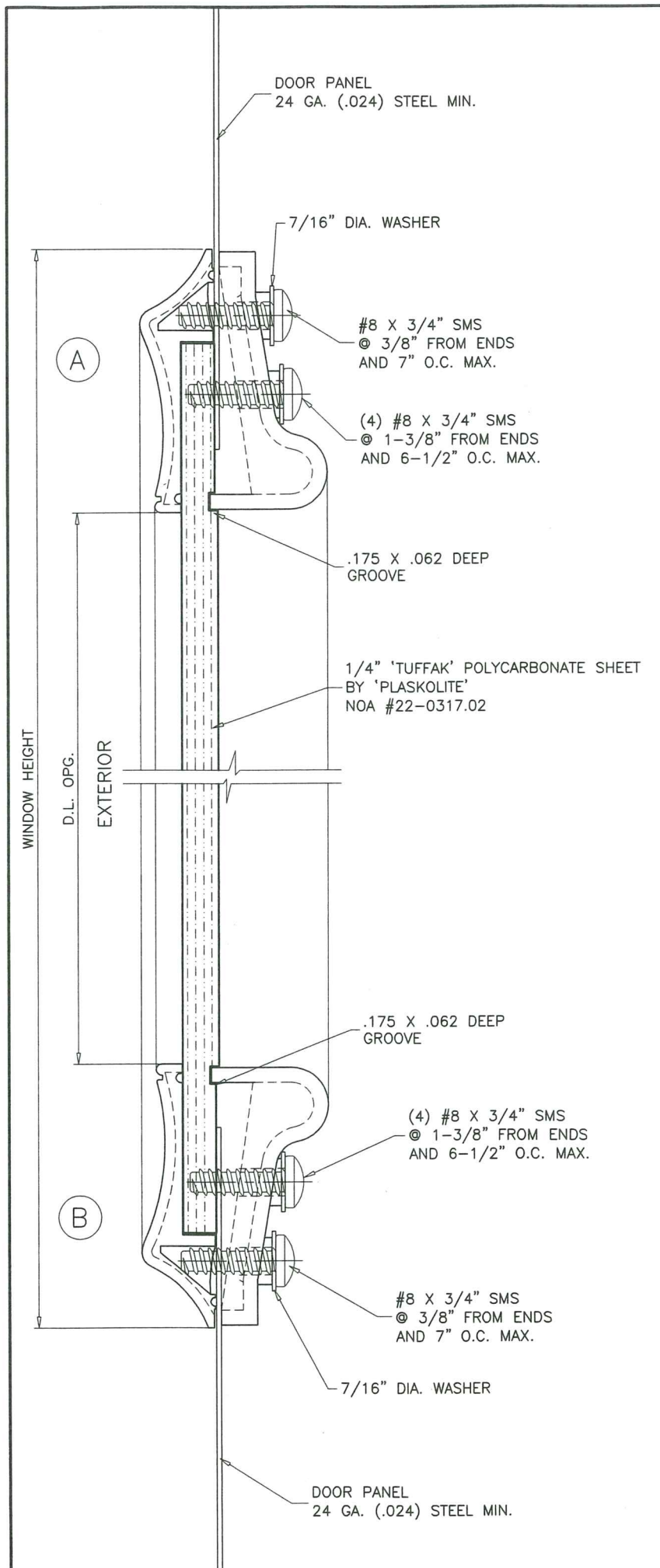

* PLASTIC COMPLIES WITH
CHAPTER 26 OF FBC
SEE EVIDENCE PAGE

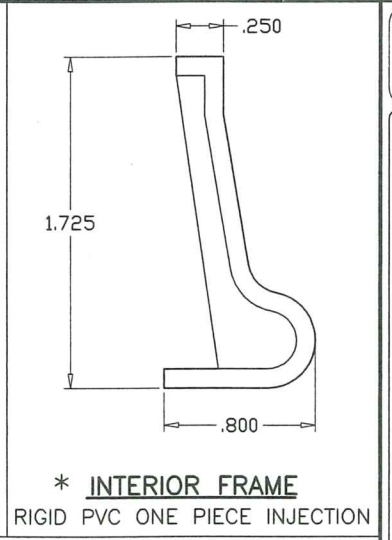
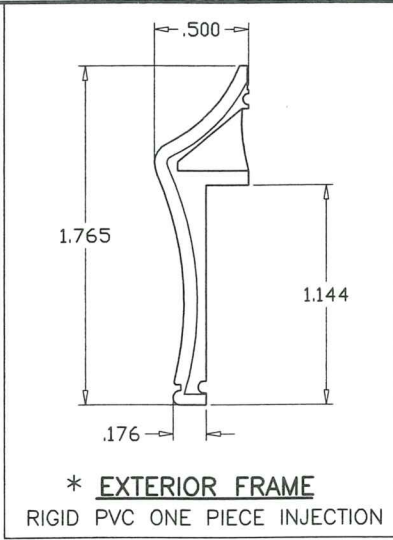

PRODUCT REVISED
as complying with the Florida
Building Code
Acceptance No 23-0710.18
Expiration Date 02/22/2025
By *Heidi A. Miller*
Miami Dade Product Control

JUN 22 2023

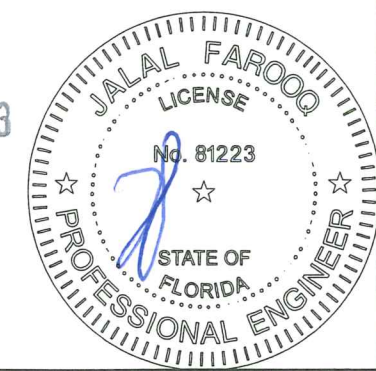

af c

AL-FAROOQ CORPORATION
ENGINEERS & PRODUCT DEVELOPMENT
9360 SUNSET DRIVE, SUITE 220
MIAMI, FLORIDA 33173 (C.A.N. 3538)
TEL. (305) 264-8100 FAX. (305) 262-6978

SECTIONAL GARAGE DOOR

DAB Door Company, Inc.
12193 N.W. 98th Ave.
Hialeah Gardens, Fl. 33018
Tel: (800) 257-2016 Fax: (305) 362-9272

no	date	description
G	09.16.14	NO CHANGE THIS SHEET
H	11.03.14	REV. PER RER COMMENTS
I	03.09.15	NO CHANGE THIS SHEET
J	10.31.17	UPDATED TO 2017 FBC
K	06.19.23	UPDATED TO 2023 FBC

date: 08-24-00
scale: -
dr. by: TARIQ
chk. by:

drawing no.
00-18

sheet 5 of 5

GARAGE\00-18DAB